



Evolution STARCH OFF ULTRA

NEW
PATENTED TECHNOLOGY

Installation and Component Guide

A LOT MORE
BOARD
STRONGER
BOARD
FLATTER
BOARD



Before



After

CLEANED IN UNDER 30 MINUTES



www.cleanprint-usa.com

EVOLUTION STARCH OFF ULTRA

YOUR CORRUGATORS ARE ALWAYS CLEAN. A COMPLETE INTERNAL AND EXTERNAL SOLUTION FOR YOUR PLANT



Evolution STARCH OFF **ULTRA**

System Installation - Component Guide

- 1 Water supply 3/4in
- 2 Y Filter Strainer
- 3 RPZ (testable non-return valve)
- 4 Pressure Limiting Valve (set at 450 kpa or 4.5 Bar)
- 5 Water softener in hard water areas only (not needed in soft water areas)
- 6 Isolation Valve (Gate valve)
- 7 Non-Return Valve
- 8 Dilution Wall - Two MixRite 10% Dosing Devices making the ESOU 20% concentrate on the daily clean
- 9 Barrel Union
- 10 Heat Exchange Unit (set at 131-149°F)
- 11 Temperature Gauge



Evolution
Starch Off Ultra
Tote & Delivery
System



Evolution STARCH OFF **ULTRA**

- 12 Hose Reel with a foaming gun and a tap with a hose at each Starch Applicator
- 13 Flow line 1in insulated Copper, Stainless Steel or Pex Ring Main to Foam Guns
- 14 Circulating Pumps (brass)
- 15 Tee (Return pipe line to Heat Exchange Unit)
- 16 Evolution Starch Off Ultra Tote and Delivery System

On completion of the installation we will walk the appropriate person the plant choses (fitter that participated in the installation) through the system. Ecochem/Clean Print will spend a day explaining the system to the operators to ensure correct understanding of operation.

The plant will sign of that the installation is satisfactorily completed.

Then the plant will maintain the system in line with required maintenance schedule.

Ecochem will warranty the hardware if correctly maintained for 12 months.





Evolution STARCH OFF **ULTRA**

ESO ULTRA Installation





Evolution STARCH OFF **ULTRA**

Technical Installation Diagram

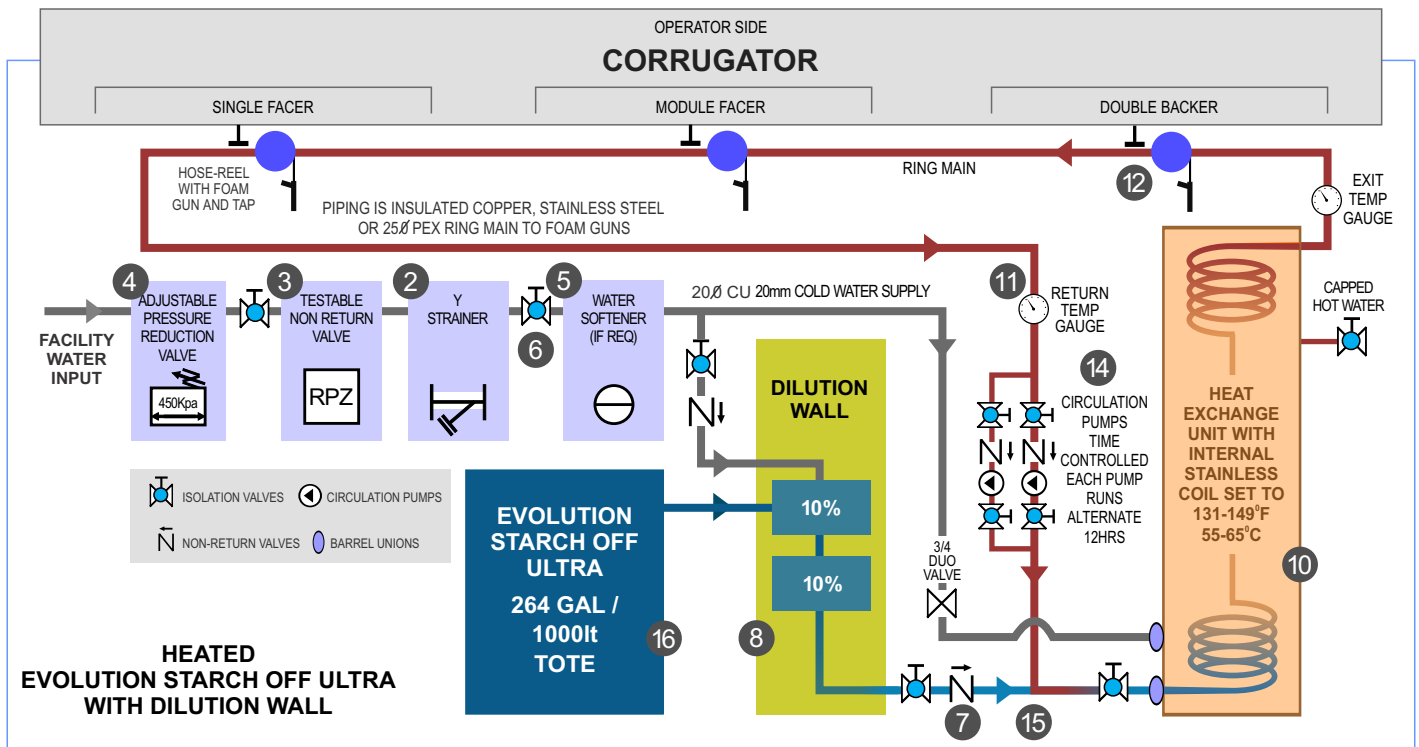

Patented Technology

Our 'Cleaning-in-Place' automatic productivity systems are patented technology offering 'End-to-End' corrugator-to-converter game changing solutions to optimize productivity.



Evolution STARCH OFF **ULTRA**

Batch Controller Instructions

1. Calculate volume of product required in gallons.
20% of tank water volume is the amount of solution required.
Thus, divide the volume of your tank by 10, then multiply by 2.

Example

If water tank volume is 137G
Then divide 137G by 10 = 14
Then multiply 14 by 2 = 28G
= (20%)

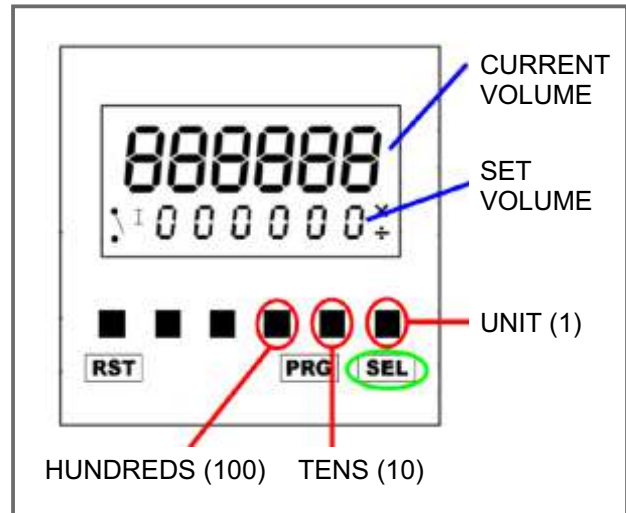

2. Enter amount from step 1.
 - 2.1. Press "SEL" button (Circled in green). Use this button to change the amount of ESO required. Once initial set up is done this does not need to be changed.
 - 2.2. Use buttons circled in red for units, tens and hundreds.
 - 2.3. Press "SEL" button when done.
3. Press "START" button on front of case
4. Pump will start up.
5. Once volume is reached the pump will stop.

In the case of an incorrect entry, reset the system by turning the power off for 10 sec and turn back on. Note: RST and PRG buttons are not used in this system.

Use emergency stop button if necessary. System will remember the last setting and metered amount for up to 5 min.

Check numbers entered before starting to ensure correct amount has been set.

EVOLUTION STARCH OFF ULTRA is optimised, unique, simple, safe and effective

Contact us now for more information and a convincing on-site demonstration



www.cleanprint-usa.com



CLEANPRINT USA
Clean Print USA, LLC
20944 Corkscrew Shores Blvd
Estero, FL 33928
Ph +1 973 220 2828



Go online to
Evolution Starch Off Ultra